

# Shape and Dimension

TENTATIVE

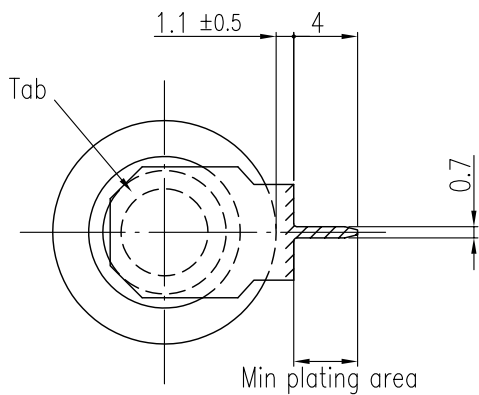
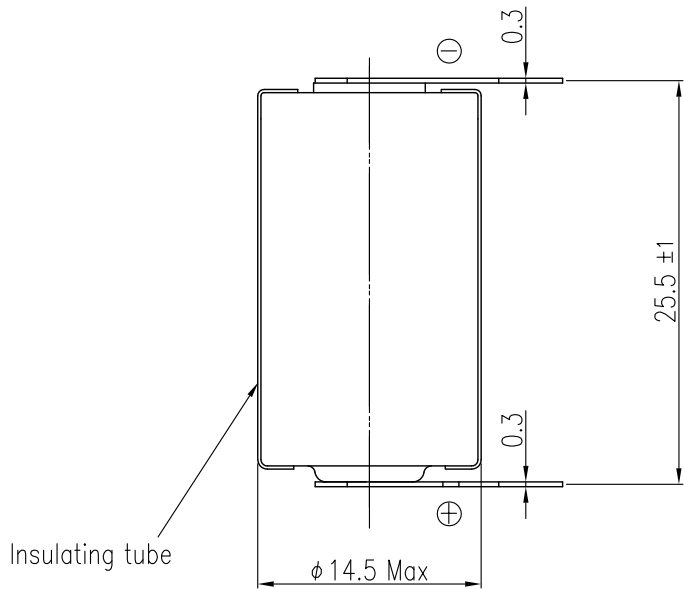
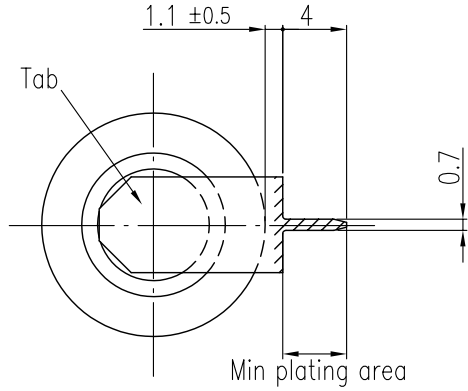

Tab material : Plated stainless steel with Sn plating  
 Tab thickness : 0.3mm  
 Welding strength of tab : Min.19.6N  
 (Vertical direction from welding plate)

Unit : mm

Do not Scale Drawing

Model	CR14250SE-P3	<p>FDK CORPORATION</p> <p>Lithium Battery Division Business Planning Department</p>
-------	--------------	---